

DESCRIPTION OF TABULATION

PART NO.	ID NO.	BARREL DIA	RM NO.	DIMENSIONS														SLOT	MATERIAL
				A	B	C	D	E	F	G	H	J	K	L	M	N	P		
MB-18	A3135	18 mm	10160109	1.63 41.5	.79 20.0	2.50 63.5	1.25 31.8	.61 15.5	.31 7.9	1.88 47.8	.75 19.1	.06 1.5	.35 9.0	.87 22.0	.45 11.5	1.04 26.3	1.15 29.1	.22 x .75 5.6 x 19.0	16 GAGE COLD ROLL STEEL

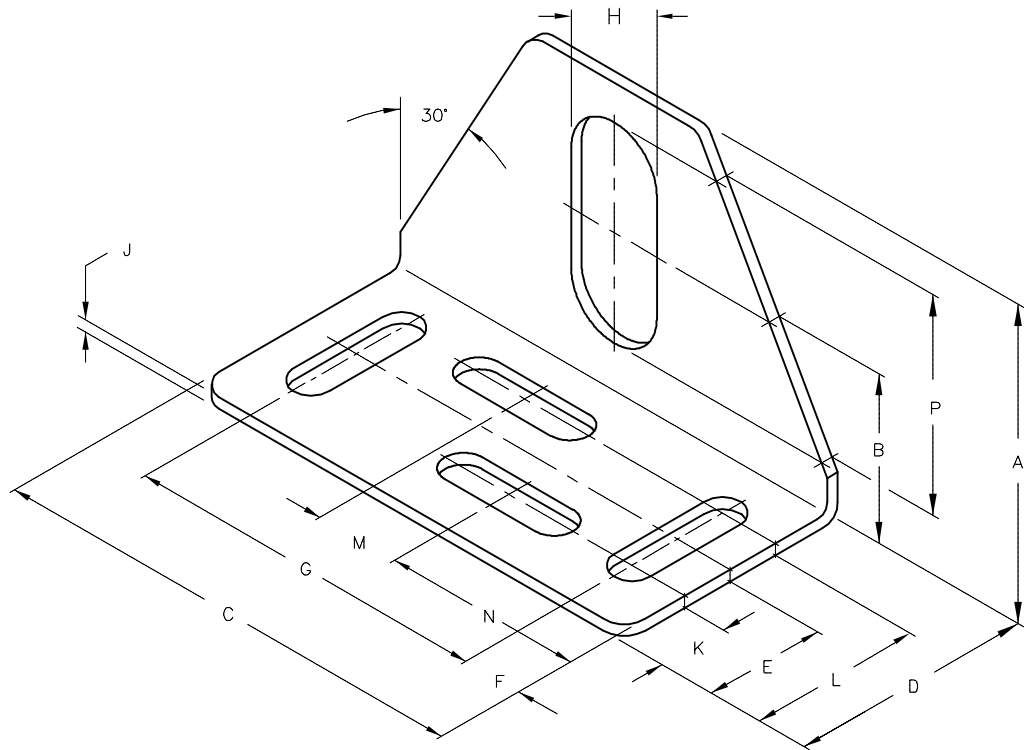

SOURCE DRAWING - FOR REFERENCE ONLY

NOTES:

- FOR USE WITH METAL BARREL SENSORS.

RELATED DOCUMENTS 1. 2. 3. 4.		3RD ANGLE PROJECTION 	THIS DRAWING IS CONFIDENTIAL AND THE PROPERTY OF TURCK INC. USE OF THIS DOCUMENT WITHOUT WRITTEN PERMISSION IS PROHIBITED.		3000 CAMPUS DRIVE MINNEAPOLIS, MN 55441 1-800-544-7769 (763) 553-7300 (763) 553-0708 fax www.turck.us	
MATERIAL COLD ROLLED STEEL		ALL DIMENSIONS DISPLAYED ON THIS DRAWING ARE FOR REFERENCE ONLY	DRFT SMW	DATE 10/17/86	DESCRIPTION MB-18	
FINISH GALVANIZED			DSGN	SCALE NONE	IDENTIFICATION NO. A3135	
REV		BY	DATE	ECO NO.	UNIT OF MEASUREMENT INCH [MILLIMETER]	
K UPDATE TO CURRENT TITLEBLOCK		RDS	07/16/02	5504	DO NOT SCALE THIS DRAWING	
REV DESCRIPTION		BY	DATE	ECO NO.	FILE: A3135	
					SHEET 1 OF 1	